

ELECTRIC SCISSOR LIFTS

COMPACT 2032E/2632E



- 6 ft 6 in stowed height (Compact 2032E).
- 32 in width.
- 770 lb platform capacity (Compact 2032E).
- 5 in ground clearance.
- Security system with Pot Hole protection.



COMPACT 2032E/2632E

Electric scissor lifts

The Haulotte® advantages

- Stowed height allows passage through standard doorways
- 32 in width allows operation in the most congested areas
- 7 ft 10 in outside turning radius ensures excellent manoeuvrability
- Pot Hole protection and load limiter in cage ensures maximum safety
- Driveable at full height
- Robust, reliable and easy to maintain design

STANDARD FEATURES

- Folding guardrails (compact 2632E)
- Non marking tires
- 3 ft platform extension
- Tilt alarm
- 2 drive speeds
- 2 front wheel drive and steer
- Free wheeling device
- 24 V - 4 x 6 V batteries
- 30 amp battery charger
- Battery charge indicator
- Hourmeter
- Horn in platform
- Towing hooks / lifting eyes
- Emergency lowering system
- Safety harness anchor points

OPTIONS & ACCESSORIES

- Motion alarm
- 59 in extension from upper control box
- Working light
- Flashing light
- 115 V - 15 A outlet

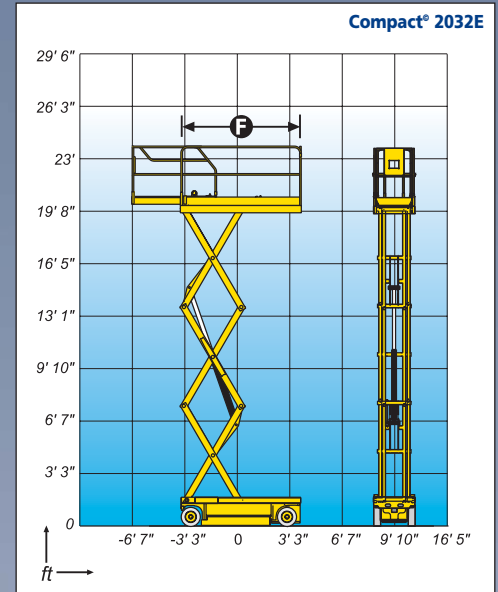
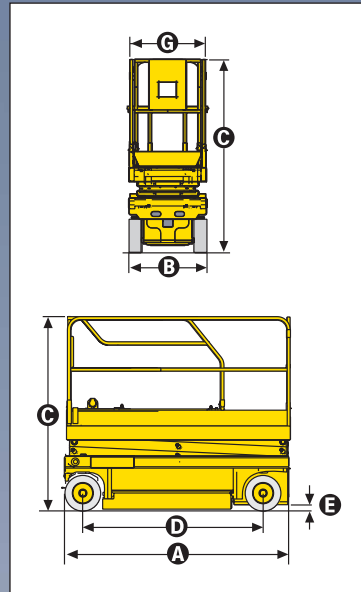

SPECIFICATIONS		
	Compact 2032E	Compact 2632E
Working height	26 ft 3 in	32 ft 3 in
Platform height	20 ft 3 in	26 ft 3 in
Driveable at full height	20 ft 3 in	26 ft 3 in
Platform capacity	770 lb	500 lb
A Stowed length	7 ft 7 in	
with access steps	8 ft 2 in	
B Width	32 in	
C Stowed height	6 ft 6 in	7 ft 2 in
Transport height	6 ft 6 in	4 ft 4 in
D Wheelbase	6 ft 1 in	
E Ground clearance	5 in	
with deployed Pot Hole	1 in	
F x G Platform size	7 ft 7 in x 2 ft 7 in	
Extension : Size	3 ft	
Extension : Capacity	330 lb	260 lb
Drive speed	0.6 mph - 2.2 mph	
Inside turning radius	13 in	13 in
Outside turning radius	7 ft 10 in	
Lift / lower speed	37 / 41 sec	51 / 42 sec
Gradeability	25%	23%
Tilt Alarm	2°	
Controls	Proportional	
Batteries	24 V / 225 Ah - C20	
Tires (solid / non marking)	15 x 5 x 2 in	
Hydraulic tank	6.6 gal	
Weight	3,815 lb	4,760 lb

ANSI/SIA A92.5 and CSA/B354.2 Standards Compliance



HAULOTTE US INC • 1530 Tilco Drive - Suite B • Frederick, MD 21704 - USA
Toll free : +1 877-HAULOTTE • E.mail : sales@us.haulotte.com • www.haulotte.us

HAULOTTE US INC • 1925 Shiloh Road • Building 3, Suite 400 • Kennesaw, GA 30144 - USA • Phone : 770-795-1111 • Fax : 770-795-1118

Haulotte 
GROUP